

Specifications

Model No.	MLS-3751/3751L	MLS-3781/3781L
Power supply	120V single phase, (50–60Hz) 15.8A or above 220V single phase, (50–60Hz) 9.1A or above 230V single phase, (50–60Hz) 8.7A or above	220V single phase, (50–60Hz) 18.2A or above 230V single phase, (50–60Hz) 17.4A or above
Power consumption	1.9kW (120V only), 2kW	4kW
External dimensions (W x D x H) mm (inch)	478 x 632 x 748 (18.8" x 24.9" x 29.4")	478 x 632 x 965 (18.8" x 24.9" x 38.0")
Weight	61kg (134 lbs.)	71kg (157 lbs.)
Chamber dimensions (diameter x depth) mm (inch)	ø370 x 415 (ø14.6" x 16.3")	ø370 x 630 (ø14.6" x 24.8")
Effective chamber height including recess in lid	463mm (18.2")	688mm (27.1")
Effective capacity	50 liters (1.8 cu.ft.)	75 liters (2.6 cu.ft.)
Chamber material	SUS304 (Austenitic stainless steel)	
Maximum pressure	0.240MPa [34.8psi]	
Sterilization temperature	115°C to 135°C	
Culture medium melting temperature	60°C to 114°C	
Keep warm temperature	45°C to 60°C	
Sterilization timer	1 to 300 minutes	
Melting timer	1 to 300 minutes	
Keep warm timer	72 hrs. fixed	
Program timer	1 week (Designation: Year, month, day, hour and minute)	
Exhaust tank	2-liter polyethylene tank	
Exhaust control	Exhaust valve open temperature setting	
Safety devices	Pressure safety valve, over-temperature limiter, anti-scorch limiter, door interlock, over-pressure limiter, current fuse	
Pressure vessel type	Small-scale pressure vessel	
Accessories included	Stainless steel baskets – Large: 1, small: 1	Stainless steel baskets – Large: 2, small: 1
	Drain hose: 1	
	Exhaust tank: 1, tank mounting bracket: 1 and tip-resistant metals: 2	

*Appearance and specifications are subject to change without notice.

Process operation

Example: Instrument sterilization course

(Operating conditions: No load; Ambient temperature: 20°C;
Sterilizing temperature: 121°C, Sterilizing time: 20 min.)

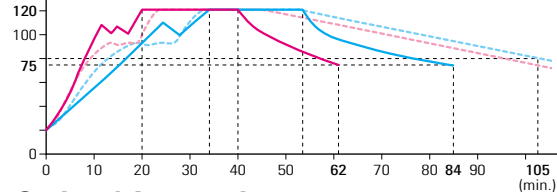

— MLS-3751/3751L
- - - MLS-3781/3781L
... MLS-3750*
- · - · MLS-3780*
*Our company's previous models

- Operating time varies depending on operating conditions.
- For liquid sterilization course, the operating time will be longer than for instrument sterilization course.

Optional Accessories

- Object temperature sensor: MLS-37SB
- Printer: MLS-37PR (with 1 roll of paper)
- Printer paper: MLS-37PR-S (5-roll set)

*Please consult your local dealer about the model number, price, delivery date, etc.

Stainless Steel Baskets and Buckets

Description	Wire Baskets		Solid Bucket	Perforated Bucket
Model	MLS-37BL	MLS-37BS	MLS-37C30	MLS-37PB30
Applicable Autoclaves	MLS-3751/3751L MLS-3781/3781L			
Appearance				
Inner Dimensions mm (inch)	ø335 x 220 (ø13.2" x 8.7")	ø335 x 160 (ø13.2" x 6.3")	ø330 x 300 (ø13.0" x 11.8")	ø330 x 300 (ø13.0" x 11.8")
Features	Stackable with no protrusions on outer surface. Stores four 1-liter flasks. Stores two tube racks (SS18-50).		No protrusions on inner surface to prevent sterilization bag from tearing. Easy-to-hold single handle. Waste materials can be put directly in these buckets for sterilization.	Stores a 3-liter flask. 2 buckets stackable.

Dimensions

Unit: mm (inch)

MLS-3751/3751L

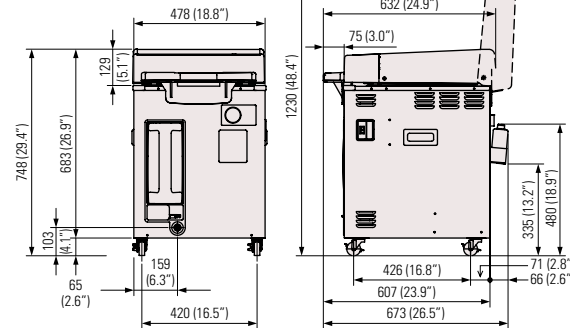

MLS-3781/3781L

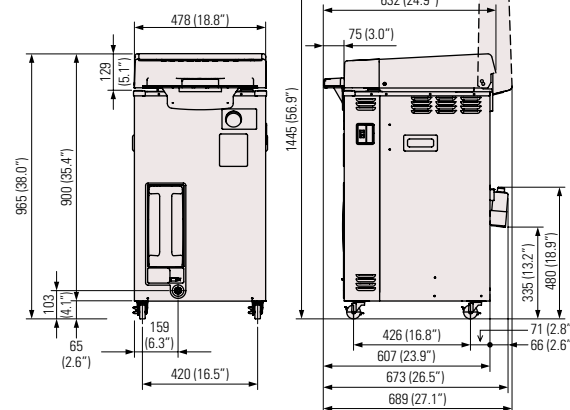

Think GAIA
For Life and the Earth

SANYO

Autoclaves for Laboratory use
Autoclaves for Medical use

MLS-3751L/3781L
MLS-3751/3781

Autoclaves

Compact design doesn't take up space.
Voice guidance function for increased safety.



MLS-3751/3751L

MLS-3781/3781L

Models MLS-3751L/3781L are for laboratory use, while
Models MLS-3751/3781 are for medical use.



Connect With Us



Space-efficient, convenience-minded autoclaves offer sterilization on demand, where and when you want it.

Researchers waste valuable time and energy when limited to using a centralized building autoclave.

Installation and maintenance of central autoclaves are not only costly but time-consuming. SANYO offers two solutions:

The MLS-3781/3781L and MLS-3751/3751L portable autoclaves are designed for individual lab use and can be conveniently wheeled from one lab to another. Model MLS-3751/3751L has a low enough profile to be stored under a lab bench when not in use.

Large-mouth 370mm-diameter chamber capacity with small installation space.

MLS-3751/3751L Load example

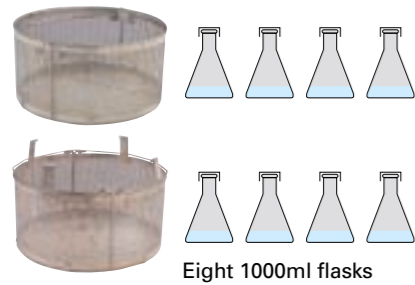

Eight 1000ml flasks

MLS-3781/3781L Load example

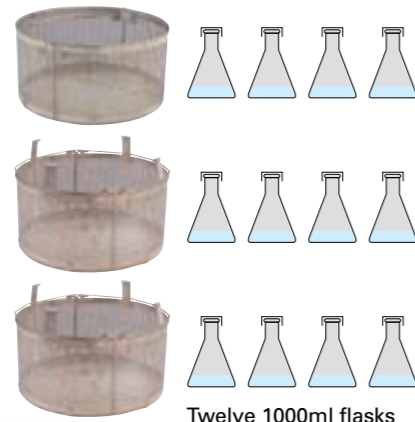

Twelve 1000ml flasks

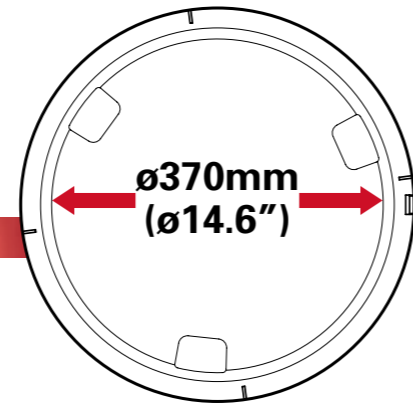

Bottom of inside of chamber (flat diagram)

Surprisingly Large Chamber

Despite the compact outer dimensions of these autoclaves, they store 8 (MLS-3751/3751L) or 12 (MLS-3781/3781L) 1,000ml flasks. The MLS-3751/3751L has two baskets, and the larger MLS-3781/3781L has three.

Compact Design, Swing-up Lid for Easy Access

Both SANYO models can be easily installed in minimal space. A swing-up lid provides effortless access for loading and unloading test tubes, flasks and lab instruments.



Voice guidance function increases safety to prevent operating mistakes and increase carefulness.

Standard Mode

For safe use of the product, precautions and operating instructions are given by voice guidance.

Warning Mode

If a safety device is activated during use and the product stops operation, the voice guidance will inform users of verification/inspection items. In addition, messages urging periodic maintenance are also provided.

Condition	Voice Guidance
Operation	<ul style="list-style-type: none"> Please check the water level in the front exhaust tank. Did you check the water level in the chamber? You have finished the setup. Press the start button to begin operation. The lid is not completely closed. The temperature inside the chamber is higher than the set temperature. This is the liquid sterilization program. Please set the sterilization temperature. The liquid sterilization program is running. The liquid sterilization program is finished.
Open the lid	<ul style="list-style-type: none"> Please be careful of hot steam when opening the lid.
Warning	<ul style="list-style-type: none"> A safety device has been activated. Please check the water level in the chamber. Please check if the exhaust hose is closed or kinked. It is time for scheduled maintenance. Please check the unit for proper operation.

A partial list of the voice guidance messages is shown.

The Voice Guidance of the product is nothing more than an auxiliary function.

For safe use of this function, please read the precautions and instructions for use in this manual.

Newly designed handle lets users open and close the lid easily with one hand.

The conventional slide handle has been completely redesigned to develop a hand-pull system that enables easy opening/closing by gripping with one hand. In addition, the cover is equipped with a scalding prevention guard to prevent scalding due to steam.

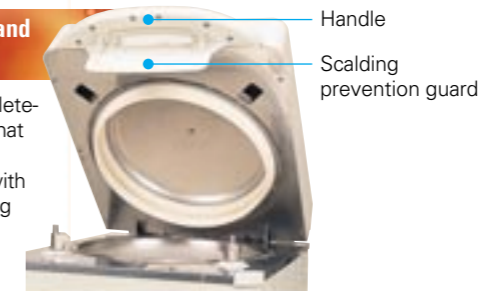

Handle

Scalding prevention guard

Plus a Wealth of Other Important Features

Functions for user safety and cooling fan/exhaust level adjustment to reduce cooling time.

Conforming to the requirements of IEC standards, when using sterilizing liquid the temperature when opening the cover is set to 65°C or less. In addition, by adding exhaust holes at several positions on the side of the product and positioning the standard-equipment cooling fan under the chamber, cooling efficiency and sterilizing efficiency are increased, so that operating time can be reduced. Furthermore, a constant open/close interval (with 5-step adjustment) for the exhaust process valve enables selection of the exhaust rate for steam inside the chamber to enable cooling in a shorter time while reducing exhaust time and preventing boiling over of sterilizing liquid.

Rough Standard of Exhaust Rate

Figure Indicated	1	2	3	4	5
Exhaust Rate %	Full close	←————→			Full open

Thermal printer (optional)

The work conditions shown on the control panel (temperature/pressure inside chamber, sterilizing course, time) can be printed out by a line thermal dot printer for record-keeping, management, and storage.

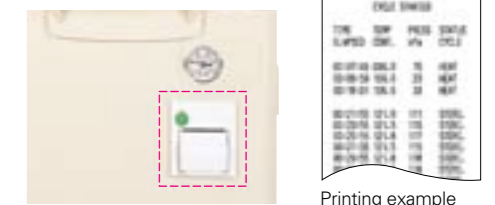

Printing example

Microprocessor temperature control

Sterilizing temperature is controlled to within +2°C/-0°C of the set temperature in the range of 115°C to 135°C.

Air vent control

Can be set to allow automatic release after sterilizing is completed.

Equipped with 4 selectable courses and 3 customizable programs

Any of 4 courses can be selected according to the purpose of use, and 3 types of setting values can be stored for each course according to the usage conditions. The setting values (sterilizing temperature, sterilizing time, melting temperature, melting time, keep warm, exhaust temperature, exhaust rate) for each program can be easily changed for the user for easy use.

• Settable ranges are shown at right.

Setting example

Cycle	Program	Steriliz. Temp.	Steriliz. Time	Heat-retent. Temp.
1. Sterilizing	1-1	121°C	27 min.	—
2. Sterilizing/Keep Warm	2-1	121°C	27 min.	50°C
3. Melting/Keep Warm	3-1	Melting temp. 100°C	Melting time 30 min.	50°C
4. Instrument Sterilizing	4-1	135°C	3 min.	—



Control panel (Illustration)

1. Sterilizing

For water, culture media, reagents and other fluids. After completion and cooling to a selected temp., air is expelled automatically through the exhaust valve.

Sterilizing temp.: 115°C to 135°C
Timer: 1 to 300 min.
Exhaust temp.: 0°C to 45°C.

2. Sterilizing/Keep Warm

After sterilizing culture media, reagents and other liquids, and cooling down naturally to a selected temp., air is expelled automatically from the exhaust valve. High temp. prevents solidifying.

Sterilizing temp.: 115°C to 135°C
Timer: 1 to 300 min.
Exhaust temp.: 0°C to 45°C
Incubation temp.: 45°C to 60°C.

3. Melting/Keep Warm

To melt or keep culture media at a fixed temp. (This function is not for sterilizing but prevents solidifying).

Melting temp.: 60°C to 114°C
Timer: 0 to 300 min., 72 hrs.
Incubation temp.: 45°C to 60°C

4. Instrument Sterilizing

For flasks, beakers, test tubes, other lab instruments. When completed, the exhaust valve opens and the temp. drops to 100°C. Thus, cool down period can be shortened. Suitable for equipment that can withstand sharp drops in pressure and for sterilizing waste.

Sterilizing temp.: 115°C to 135°C
Timer: 1 to 300 min.