

*Anatomage*

TABLE



سوماتکو  
SOMATCO  
www.somatco.com



# Why the Anatomage Table?



## Advanced Educational Tool

The accuracy of the real human anatomy and the quantity of clinical examples are unique aspects of the Anatomage Table. Combined with powerful hardware and software, the product offers unprecedented technology for medical education. Students are motivated and can easily digest complicated 3D shapes of human anatomy which makes the Table very effective for anatomy education.

## Technical Showcase

The Anatomage Table features highly advanced technology that draws attention from visitors as well as your students and faculty. The product will quickly become the technological centerpiece at your institution that sets you apart from other institutes.

## Multipurpose

The Table is not only used for anatomical education. The Anatomage Table has been cleared by the FDA for applications in medical diagnosis as well as clinical use. It can be utilized as a powerful radiology workstation, as well as a tool for surgical case review, patient consultation, and medical research.

## Cost Reduction

Unlike cadavers, the Anatomage Table does not require ventilation infrastructure, embalming equipment, personnel, or storage. The contents are reusable, so there are no recurring acquisition costs. The product will save significant costs over the long term.

## Clean and Safe

The Anatomage Table offers a high quality lab experience without any chemicals. There are no possibilities of leaks, no environmental concerns, and no additional ventilation requirements. The product provides headache free lab sessions.

## Compare

	Anatomage Table	Cadaver Lab		
Chemicals	No	Formaldehyde, methanol, phenol, & other solvents		
Facility	No special requirements	Ventilation, freezer, storage, & disposal		
Restrictions	No restrictions	May require permits & restrictions		
Number of cases	Unlimited number of cases	Single case for each student		
Recurring cost	Minimal	New cadaver acquisition every year		
			Anatomage Table	Models
Anatomical accuracy	Real human body		Simple	Artistic model
Cutting and sectioning	Any direction		No cutting	Limited
Size	Life size		Life size	Computer screen
Number of cases	Unlimited; large number of cases		Limited; small number of cases	1 or 2

“For surgeons, residents, fellows, and every level of education it is a new opportunity to be able to learn anatomy in a different manner that’s very very efficient.”

— David Thiel, M.D., Associate Professor of Urology  
Mayo Clinic, Florida



# Applications



## Full Lab Replacement

The Anatomage Table is sufficient to cover the full anatomy class. High accuracy and rich contents offer an excellent replacement to traditional cadaver based dissection. Since the data preserves the real life patient color and shape, the Table is more effective than embalmed cadavers.

## Pre or Post Lab Review

The Anatomage Table is an excellent supplement to be used in conjunction with existing cadaver dissections. The Table can be used in labs for procedural instruction. With its segmentation features, each system or anatomical structure can be separated and reviewed individually. The class' embalmed cadavers can be CT scanned and reviewed on the Table so that the students can review a virtual and real body at the same time. Also, the Table is excellent for post dissection review. This kind of technology significantly advances existing curricula.

## Lecture

The Table can be used directly during lectures since it connects to projectors and allows for prepared presets to be preloaded. Instructors can create and demonstrate procedural material, making lectures more dynamic and engaging so students can absorb the material more effectively. Screen captures and short video clips can be saved and shared with students as review material. Thus, running a full lecture with the Table makes a traditional, difficult class into an exciting, high quality one—enriching the curriculum.

## Pathological and Procedural Training

A strong pathological and procedural training tool, the Anatomage Table features are derived from FDA approved surgical planning software that merges actual 3D device models onto a patient image. This allows life size simulation of the device interacting with the real patient image. This feature allows a new kind of medical device training that does not use any animal or physical specimens.

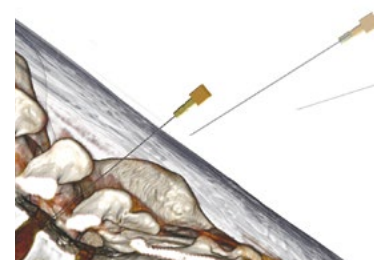
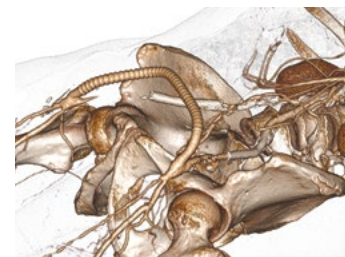

## Focal Point

In a public setting the technologically advanced Anatomage Table never fails to draw attention. The Table's intuitive interface allows anyone to approach and explore human anatomy.



## Forensic and Virtual

CT scanning is becoming increasingly popular in the field of forensic and archaeological sciences. The Anatomage Table has already played a crucial role in the historic discovery and investigation of the Pharaoh Tutankhamun's cause of death, which was documented by Fuji TV and PBS in August 2012, and revisited by STV and BBC in October 2014. The Table's forensic and virtual autopsy applications were also discussed favorably in a 2013 Scientific American article.



## Patient Consultation

Visualization is easier for patients when viewing their anatomy in 3D color as opposed to 2D black and white slices. With this technologically impressive visual consultation, the patient's visit will be much more effective.

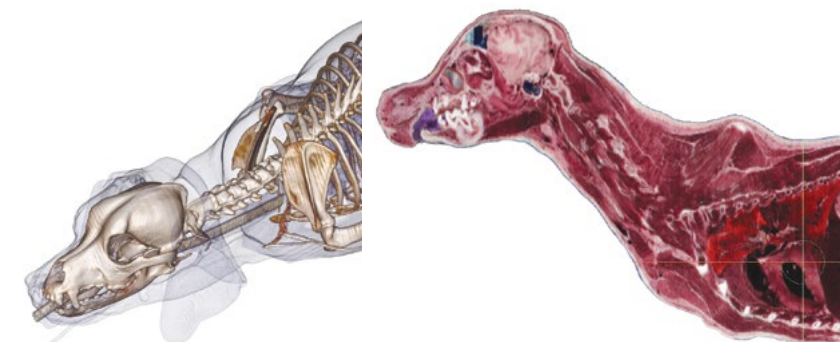

## Veterinary Usage

The Table is an ideal instrument for veterinary professions. Compare anatomy of different animals for education or research, load your own veterinary scans for instruction or case planning, and study animal anatomy. Included in the Digital Library are full-body cat and dog cadavers based on real tissue data, as well as 40 other CT scans from various species.

# Features

## Gross Anatomy Contents

The Table comes with both full body male and female gross anatomy. The full external and internal gross anatomy is volumetrically displayed from head to toe. The images are created from non-chemically treated frozen cadavers. Thus, the color and shape are preserved, illustrating the accurate anatomical realism of a living human. The virtual body can be cut anywhere in any way, revealing the details of the internal structures.



## Interactive Cutting and Segmentation

The Table offers unique touch interactive cutting tools. With their fingers, users can rotate the virtual body and cut in any direction. After the cut, the cross section shows the details of the internal structure. Users can scroll through the plane of the last cut or cut again to further explore the anatomy. Unlike a real body, a cut can be undone to restore the body instantaneously. Such dissection capabilities set the Table apart from any other simulation system. With the ability to practice dissections over and over again, the Table becomes a very effective anatomy learning tool.

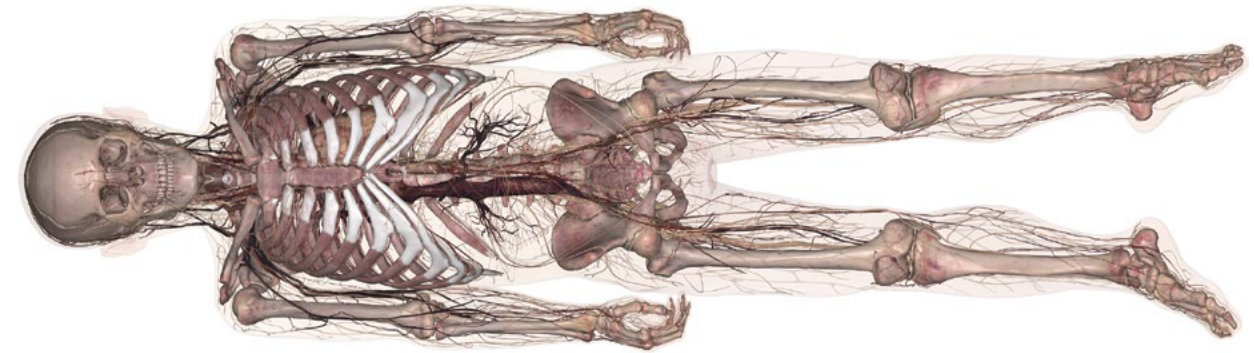

## Regional Anatomy Contents

The Table also provides high resolution regional anatomy at 0.4mm to 0.1mm. Such high resolution allows for the viewing of detailed structures such as small nerves or blood vessels that are difficult to observe by any other means. The regional content covers the head and neck, thorax, abdomen, pelvis, joints, and most other regions of the body. These contents are useful for teaching the details of regional structures.

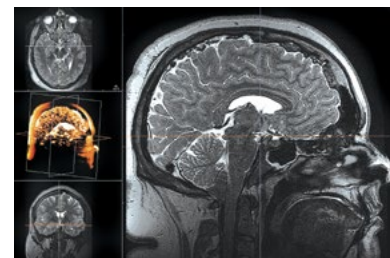
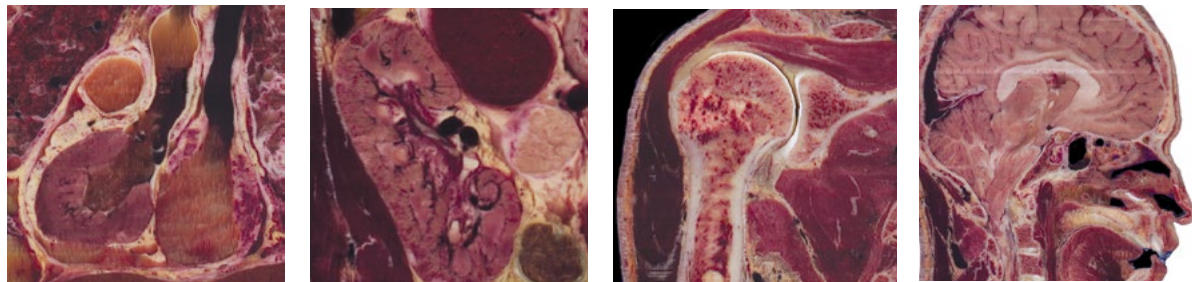

## Radiological Imaging Workstation

The Table doubles as a radiology workstation. It opens any medical imaging data and provides high quality interactive 3D renderings. Whether it is your own scan or one of the cases in the optional digital library, the Table gives full 3D anatomy that can be intuitively controlled. The window level control allows examination of soft tissue or hard tissue. Users can also review images in a traditional radiology format. The workstation is useful for both studying various pathological examples and reviewing patient scans.

## Annotations

Over 1000 structures of gross anatomy are fully annotated and segmented. Users can explore the body by picking points of the anatomy with their finger and having the Table display the name. Users can also locate a structure from lists of systems, categories, and structures. Such interactive annotations make the Table a quick, efficient anatomical reference system.

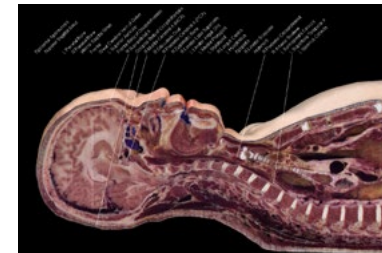

## 1:1 Life Size Display and Bed Form Factor

One of the important features of Table is that it can display anatomy in 1:1 life size. Also, the Table's form factor resembles an operating table or hospital bed. By reviewing the body in life size on the Table, students learn how to perceive an actual patient lying on a bed, helping them with the difficult task of connecting the anatomy they learn in class to the real world patients they will treat. The Table offers a more effective education for students who will one day serve in the healthcare field.



# Digital Anatomy Library

## Clinical Cases

The Table has an optional digital library module that includes over two hundred and fifty clinical cases, allowing students to not only dissect normal gross anatomy, but also experience abnormal pathologies. The user interface makes it easy to search for scans by regions of the body and includes notes on each case.

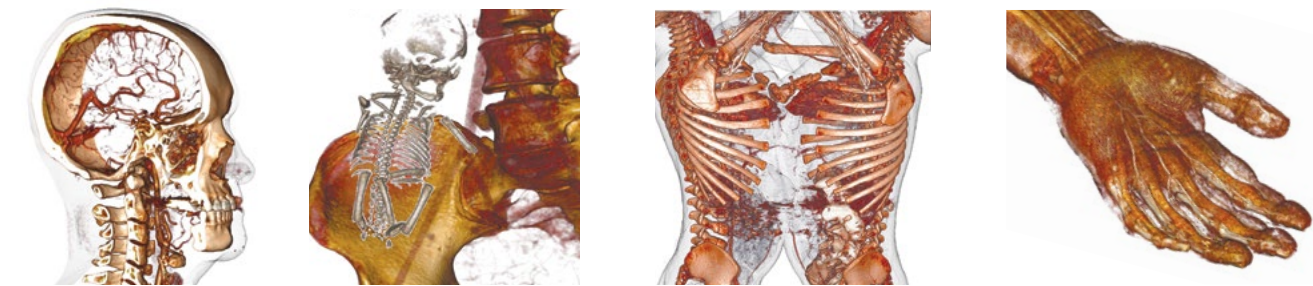
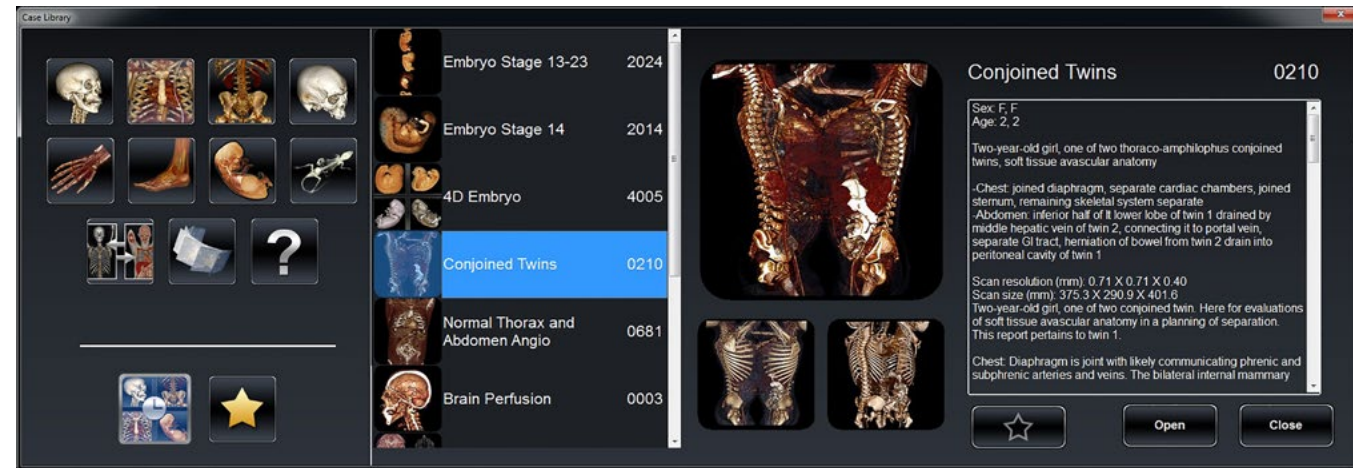

## 4D Scans

As part of our commitment to pushing the bounds of digital scan imaging, Anatomage has added 4D scans to the latest table offerings. Visualize beating hearts and respiration with full interactivity.

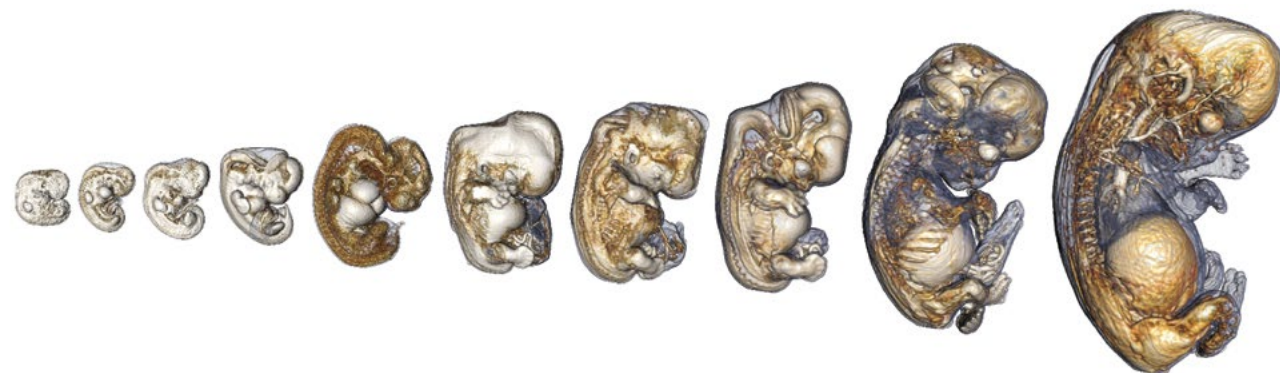

## Comparative Analysis

Furthermore, the digital library offers comparative study cases with synchronized dissections of multiple cases. Open three related cases at a time. A great tool for studying comparative anatomy.

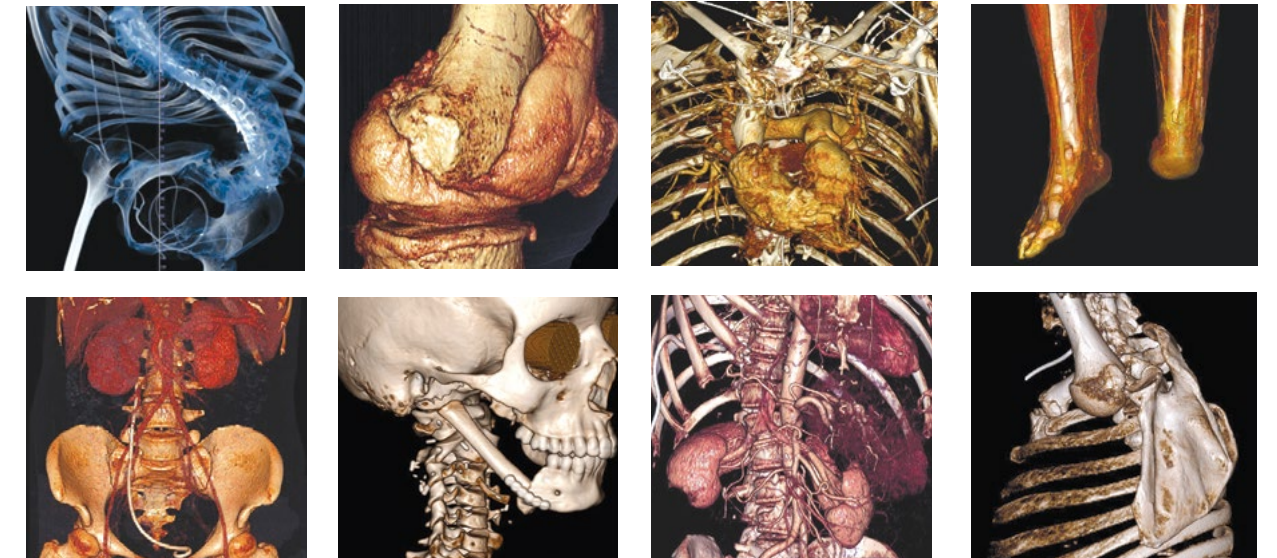
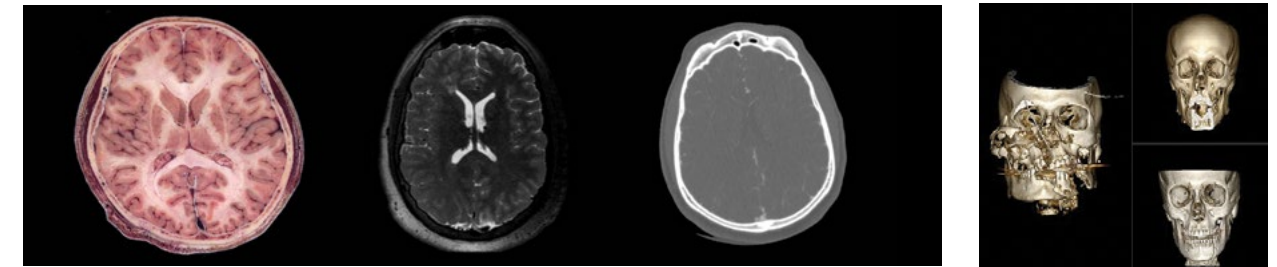

*“The ability to view a large variety of CT and MRI scans is unique and infinitely useful.... Anatomy courses including identification of structures seen in cross sectional anatomy, x-ray, CT or MRI slice data, pathologies or abnormalities, anatomical variations, fractures, or cardiovascular conditions or diseases will find the Table an excellent method to both instruct and test students in these regards.”*

—W. Paul Brown, DDS, FICD, FACD  
Stanford University, Division of Clinical Anatomy

# Building Your Curriculum

## Award-winning Volumetric Software

Every Table comes with a copy of Anatomage's renowned medical imaging software, Invivo, that can be installed on a separate workstation. Invivo shares the same underlying software as the Anatomage Table and is FDA approved for clinical applications. Invivo and MD Studio expand on the capabilities of the Anatomage Table by providing additional tools for content creation, such as the ability to three-dimensionally annotate, segment, or overlay digital models of medical devices directly onto patient scans. All Invivo and Medical Design Studio features are compatible with the Table and can be used for immediate and effective demonstrations of device design and operation on a life-size scale.

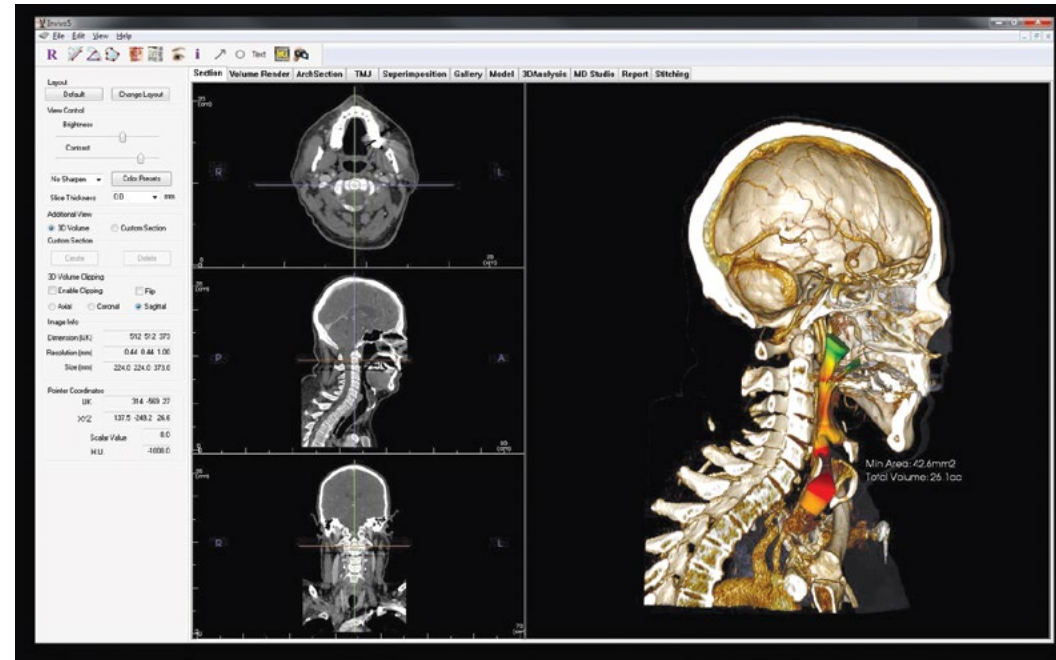

## Perform and Capture Simulations

Segment any patient scan data and create digital models. With Invivo's built-in video capture tool, these simulated movements can be captured and shared easily.

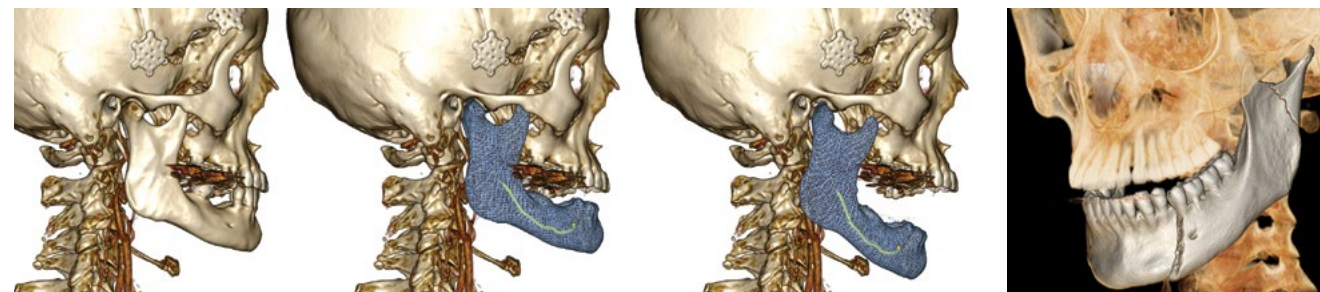

## Radiology Workstation

Invivo and MD Studio are a high performance, volume rendering package comparable to other expensive radiology software. Open any patient scan (MRI, CT, PET) for immediate 2D slice viewing or instant 3D reconstruction. Users can make measurements both in 2D and 3D for clinical or research applications.

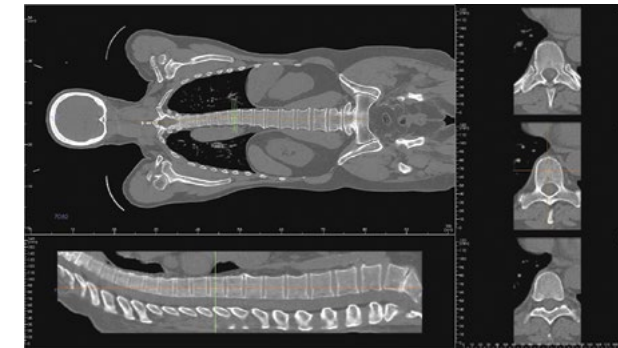

## The Anatomage Curriculum

The Anatomage Curriculum features an integrated, intuitive interface allowing instructors to cover human anatomy by region and system. Teach comparative, clinical anatomy using real patient data in the form of annotated, relevantly displayed scans from the Table's Digital Library. Anatomage has always worked to lower the Table's learning curve for instructors; the Anatomage Curriculum has been built to make the inclusion of the Digital Library's vast content into your own classroom as efficient as possible.



## Classroom Integration

With straightforward pin-drop functions and software access controls, instructors have the necessary tools to test directly from the Table's content. Create entire lab practical examinations or simple discussion-section quizzes using any of the full-body cadaver tissue data, high resolution regional scans, digital library scans, or Anatomage Curriculum data sets.

# Hardware Features

# Specifications

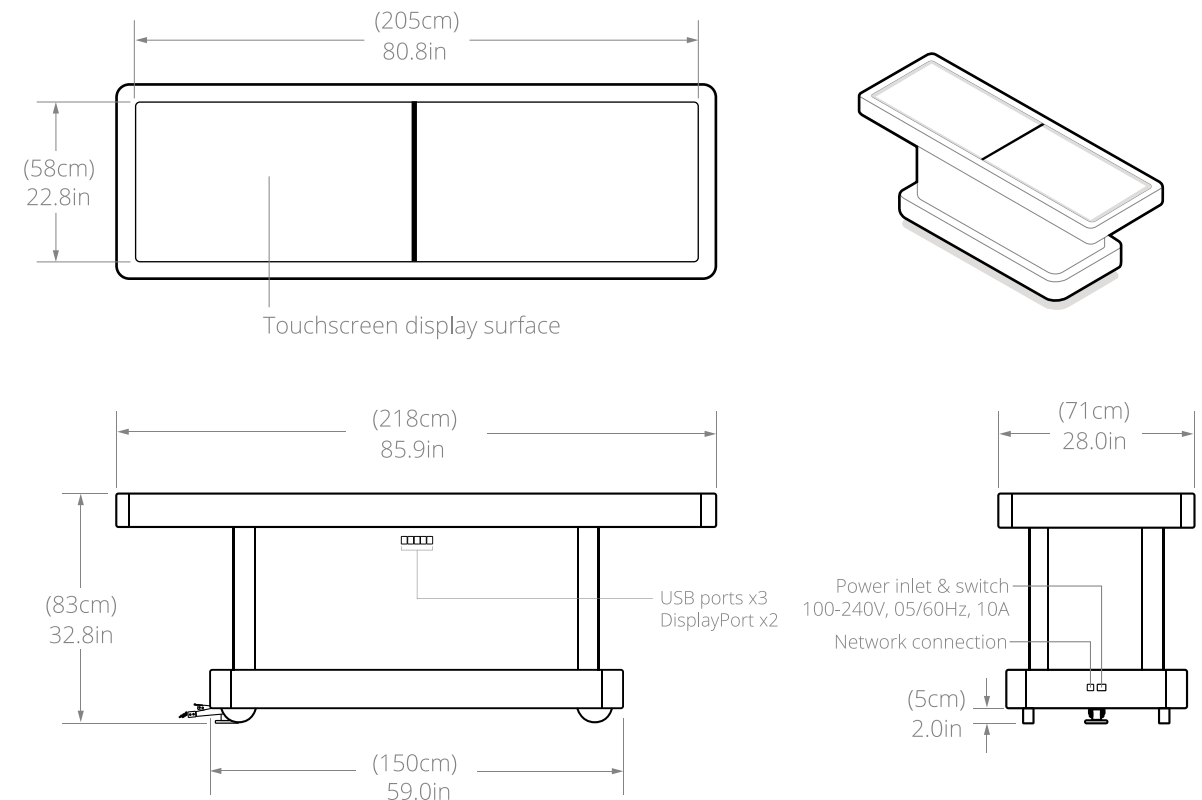

Category	American System	Metric System
Product Dimensions	Length: 87" Width: 28" Height: 35.5"	Length: 2.2 m Width: 0.7 m Height: 0.9 m
Weight	300 lbs.	136 kg
Screen Dimensions	85" (22.5" x 81.5")	216 cm (57 cm x 207 cm)
Screen Resolution	3840 x 1080	3840 x 1080
Screen Brightness (Typical / Max)	500 nit / 700 nit	500 nit / 700 nit
Wheel Dimensions	5"	13 cm
Power Type	Internal	
Power Supply	AC 100-240 V, 50/60 Hz, 10A	
Power Consumption	On Mode Sleep Mode Off Mode	1150 W (max) / 850 W (typ) Less than 20 W Less than 1 W
Operating Temperature**	0°C ~ 40°C	
Humidity**	10 ~ 60%	

\*\*Refer to safety instructions and warnings when operating the Anatomage Table

# Worldwide Innovation

## Anatomage Community

When you purchase an Anatomage Table you not only get all the high quality contents developed by Anatomage, you also gain access to a global community of educators and researchers who have already spent time developing their own content and ideas on how best to incorporate the Table into a wide range of curricula and disciplines. With close to 350 Tables sold around the world, Table users can expect to enjoy informative annual users group meetings and developmental programs on an international scale to help make sure that the Table will meet their needs. Anatomage distinguishes itself with cutting edge design supported by an excellent team with the drive to ensure that the Table does not just become a product, but rather a community of users.

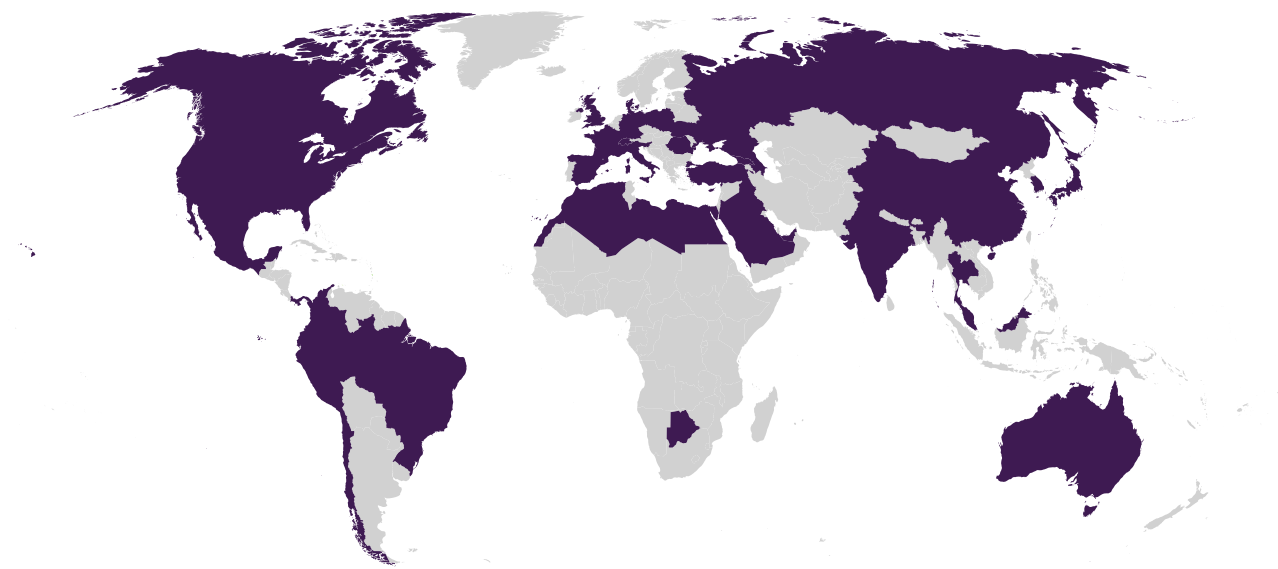

## International Distribution

The Anatomage Table is used globally—in fact, today there are Tables on every continent but Antarctica. Headquartered in California, Anatomage has two additional offices in Milan and Korea to better serve our customers abroad. We also form partnerships with only the most respectable and trusted international distributors. We currently have 26 international distributors, a list of which can be found on our website, that we trust to offer timely service in the proper language and with cultural sensitivity. In the case of sales to countries where we have not found a representative that meets our exacting standards, we handle all the arrangements ourselves, providing training and arranging shipping.

## Building Curriculum

Combining the powerful content creation tools of Invivo with the easy-to-use demonstration capabilities of the Table, Anatomage provides users with a complete platform for creating and sharing anatomy information with any audience. Load medical device designs laid over real patient data and create custom videos and images for students and colleagues. When 3D printers are available, use Invivo to export and create your own physical example models.

The Anatomage Table opens any patient images immediately and loads any content created with the Invivo software. The form-factor perfectly suits small group studies and easily projects for larger audiences as well. Away from the classroom, visiting guests and colleagues can also load their data onto the Anatomage Table for quick and seamless collaborative discussions.





## About Anatomage

For the past ten years, Anatomage has been a leading medical device company driving innovation in the healthcare industry.

Anatomage products are used in tens of thousands of clinics and hospitals both in the US and internationally. These include image guided surgical devices, surgical instruments, radiology software, imaging equipment, and display equipment. Anatomage has established partnerships with leading radiology equipment companies; they use Anatomage software as their exclusive imaging software shipped with units.

Located in downtown San Jose, California—the capital of Silicon Valley—Anatomage has thrived in a place where innovation is a part of the culture. Anatomage has been continuously developing creative, leading-edge products for the medical and dental industries since 2004. Anatomage's products have been featured in TED, BBC, CBC, Japanese Fuji TV, and PBS due to their originality and positive impact. We are proud that our products are copied by other companies; we take it as proof that our ideas are pushing the industry. Anatomage continues to lead with innovations that will set the new standard of the future.

Anatomage products are developed, designed, and manufactured following strict FDA guidance for medical device manufacturing at our facility in San Jose, California, U.S.A.. We established and maintain our manufacturing facility in our San Jose headquarter to ensure the highest quality.

Anatomage has a strong relationship with customers, whom enjoy interacting with the high caliber members of the Anatomage team—we hire biologists, medical specialists, and engineers from top schools who represent the best of their respective fields. Anatomage has also established strong ties through successful relationships collaborating with researchers and helping building curricula at many prominent universities. Anatomage is dedicated to making not only the most innovative products, but also to creating the highest quality experiences.

Jack Choi, Ph.D.  
CEO  
Anatomage Inc.



Connect With Us

